

FREESTYLE —
FERRUCCIO LAVIANI 2006

1—
5



Maximum modularity for this agile and versatile system. Linear and corner elements, classic or cushioned armrests, trapezoidal terminal elements and island units, seats and backrests of various sizes for symmetric or asymmetric combinations, additional cushions and different fabrics for monochromatic effects or in alternating tones.

FINISHES

COVERS

fabric - leather, completely removable.

Available in fire-resistant version (TB117 and BS5852).

TECHNICAL INFORMATION

SEAT

Internal structure is a solid firwood (Picea abies) frame and chipboard, with elastic straps. Padding in variable density high-resistance foam polyurethane. Light velvet cover.

SEAT WITH CUSHIONS

Internal structure is a solid firwood (Picea abies) frame and chipboard, with elastic straps. Padding in variable density high-resistance foam polyurethane. Light velvet cover. Cushion filled with flakes polyurethane and sterilised feathers, 100% cotton cover.

ARM AND BACK

Internal structure is a solid firwood (Picea abies) frame and chipboard, with elastic straps. Padding in variable density high-resistance foam polyurethane. Light velvet cover.

ADDITIONAL CUSHIONS

Cushion filled with flakes polyurethane and sterilised feathers, 100% cotton cover.

FRAME WITH FEET

Painted metal with adjustable feet in non-slip plastic.

REMOVABLE OUTER COVERS

(See attached card, specific for each cover).

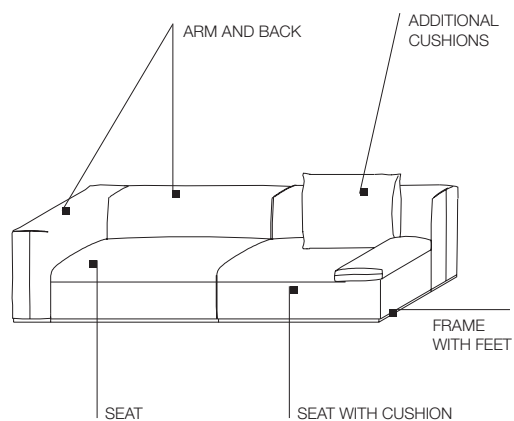

DIMENSIONS

Asymmetric back example

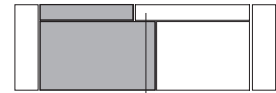
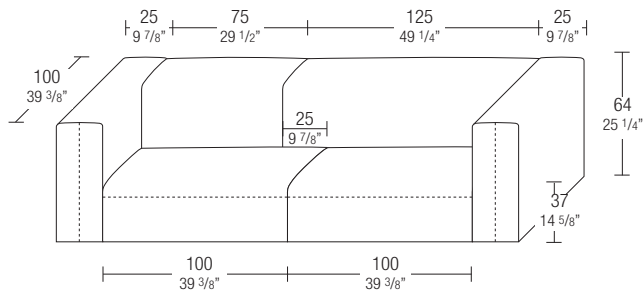

The seat-back alignment can differ by a maximum of 25 cm (9 7/8")

Seats with cushion arm

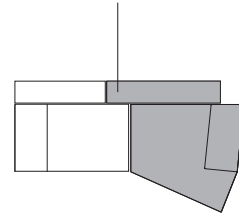
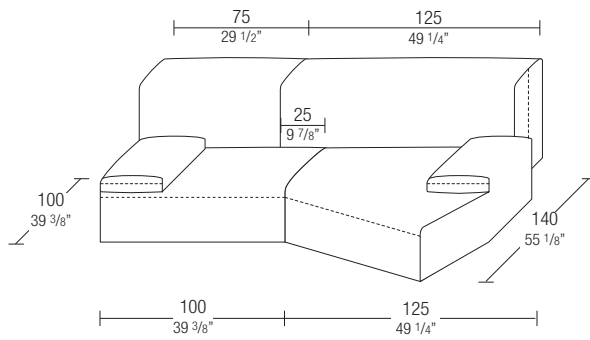

3
5

Island element

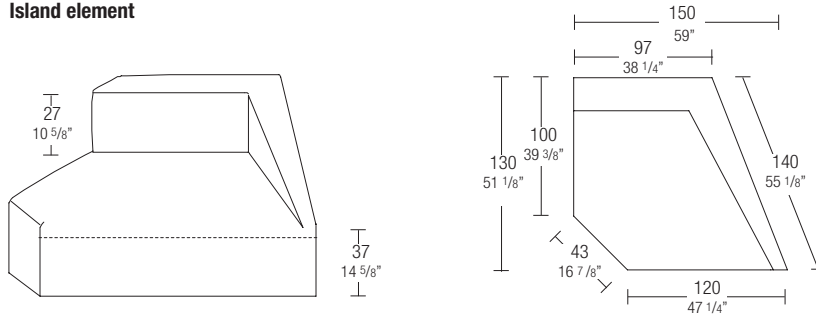

The elements next to an island must have the seat and the back aligned.

DIMENSIONS

seats

SE12

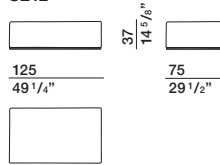

SE10

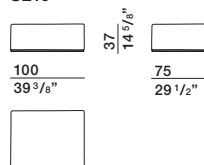

SE75

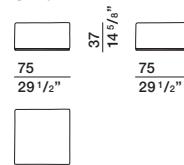

seats with cushion

SC12 dx - sx

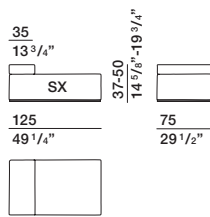

SC10 dx - sx

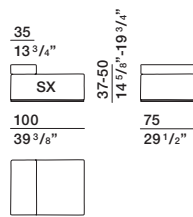

end

TE12 dx - sx

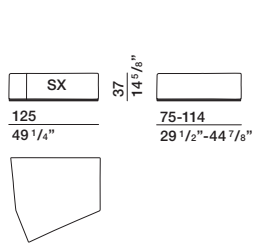

end with cushion

TC12 dx - sx

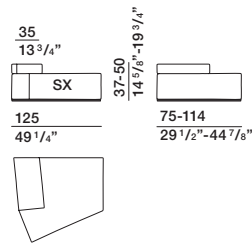

back

SH12

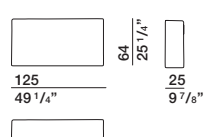

SH10

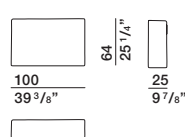

SH75

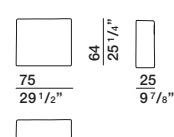

arm

BR10

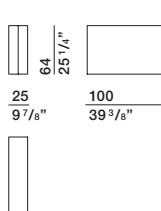

pouf

PF12

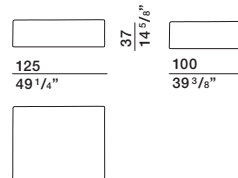

PF10

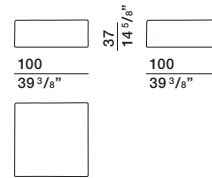

pouf

PF7575

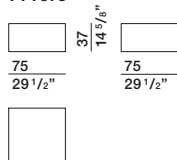

PF1075

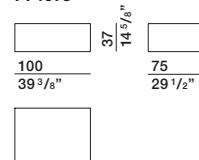

PF1275

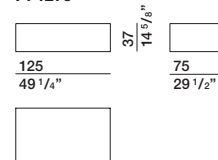

DIMENSIONS

island element

IS15 dx - sx

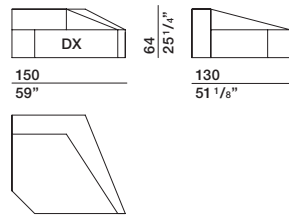

150
59"

130
51 1/8"

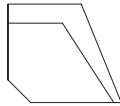

additional cushions

CU/80

CU/70

CU/60

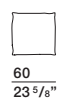
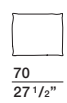
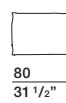

80
31 1/2"

70
27 1/2"

60
23 5/8"

SAMPLE COMPOSITIONS

composition 5

L05

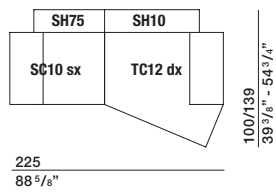

225
88 5/8"

100/139
39 3/8" - 54 3/4"

composition 11

A11

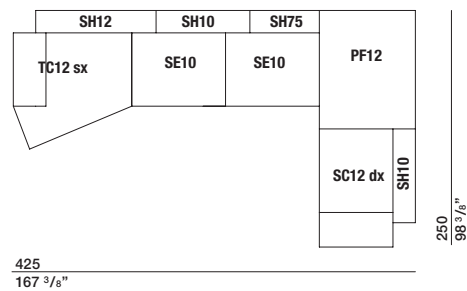

425
167 3/8"

250
98 3/8"